

Jordan Thermostatic Radiator Valves (Angled TRV)



Available Finishes	
Chrome	Brass
Antique Brass	Antique Copper
Brushed (Satin) Nickel	Black Nickel

Connection size	
Valve to Radiators	1/2" BSPT
Valve to Pipe	15 mm Compression

Allen Key size	
To adjust Lock-Shield	SW8
To fit Coupler to Radiator	SW13
Allen Keys are not included	

Pressure Ratings	
Max Test Pressure	16 Bar
Max Operating Pressure	10 Bar
Max Differential Pressure	1 Bar
Pressure Drop Value (Kvs)	1.23 m ³ /h
Kvs value is the metric measure for the flow of a fully opened valve. It is defined as: The volume flow in cubic metres per hour of water at a temperature of between 5° and 40° Celsius with a pressure drop across the valve of 1 bar.	

Flow Ratings	
Normal Flow Rate	0.42 m ³ /h
Max Flow Rate	1.23 m ³ /h

Temperature Ratings	
Max Test Temperature	100°C
Max Operating Temperature	120°C
Temperature Adjustment Range	7-30°C

Disclaimer	
All dimensions are approximate and for roughing in only.	
We recommend no work be carried out until the goods arrive.	
We can take no responsibility for errors in information supplied.	

Jordan Thermostatic Radiator Valves (Angled TRV)

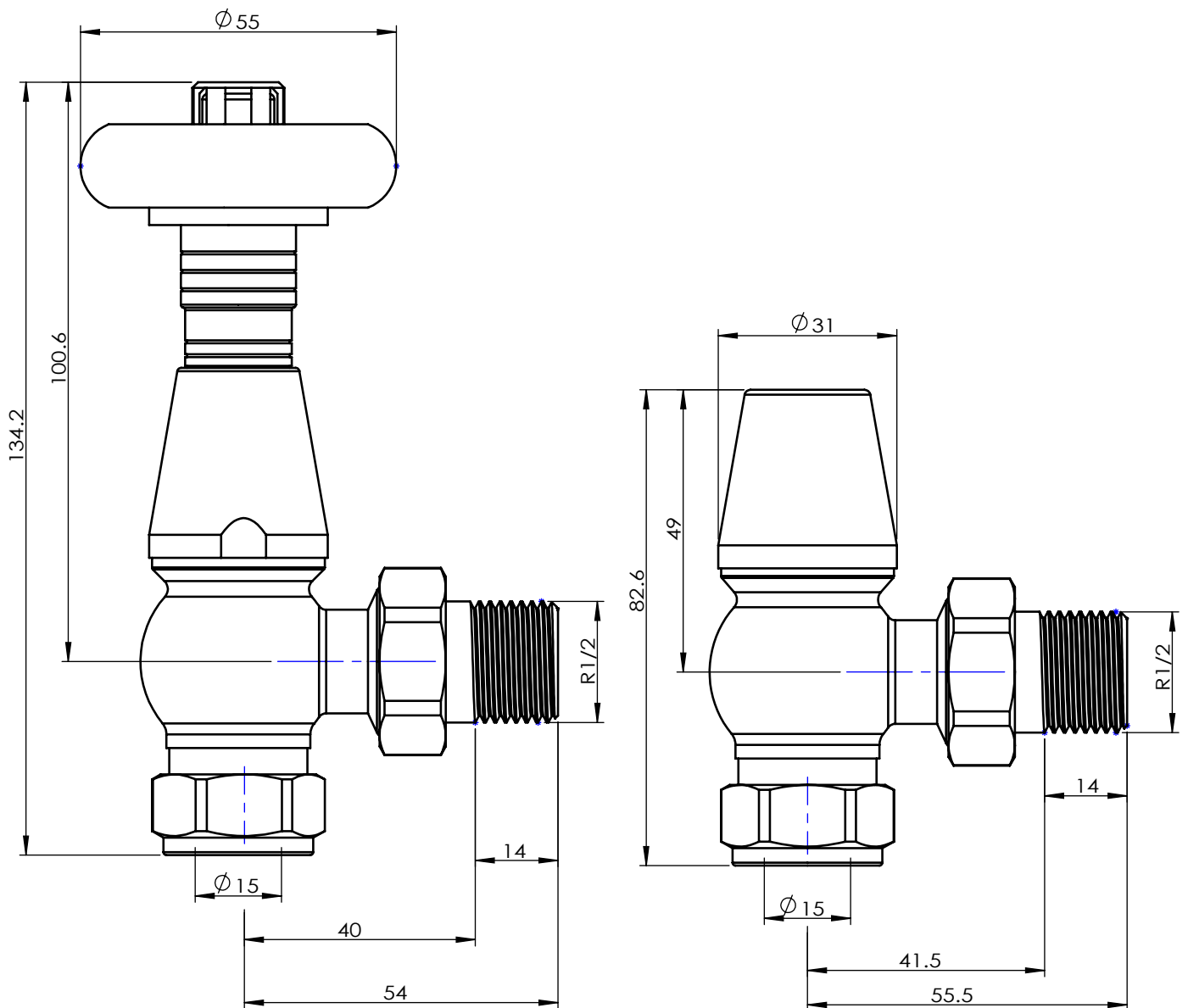

Jordan Thermostatic Radiator Valves (Angled TRV)

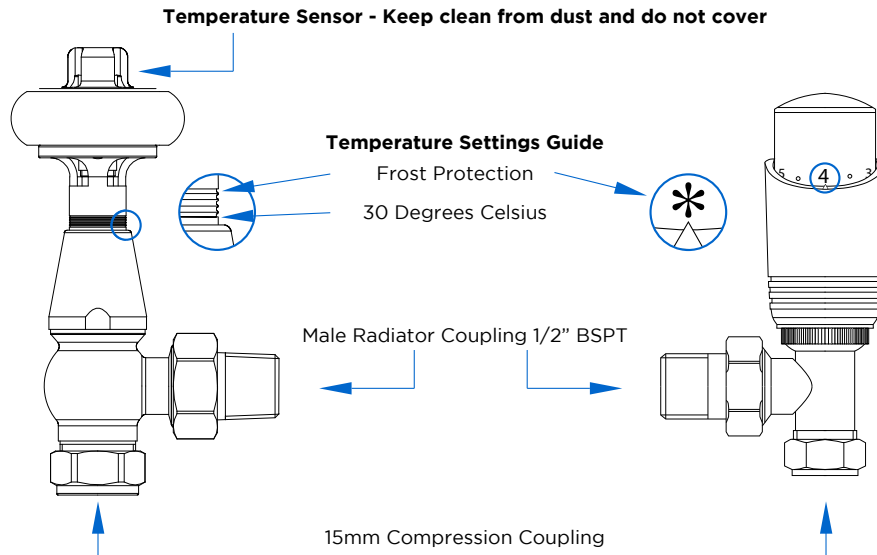

Thermostatic Temperature Control

When the wheel head is wound clockwise to the closed position the valve will still operate if the room temperature falls below 7 degrees C, providing frost protection.

When fully open the thermostatic control operates to around 30 degrees C. For traditional valves, the small grooves on the shaft can be used as a temperature guide. The more grooves showing, the higher the room temperature.

As with any valve, if fully opened (anti-clockwise) always turn the wheel head back one 1/4 turn, to prevent sticking as room & valve temperatures alter.

Installation

Your radiator valves should only be installed by a competent and suitably qualified installer. Your warranty may be void if installation is not carried out by a suitably qualified heating engineer.

All plumbing joints should be sealed using appropriate tools, methods and materials. Never over tighten any joint or coupling.

Ensure care is taken to protect the decorative finish on the valves during installation. We would recommend applying protection (for example, at least two layers of paper between the faces of the nuts and any spanner) to ensure the surfaces are not marked.

We recommend all TRV's are installed on the flow, rather than the return pipework of a radiator. When used in conjunction with a system automatic bypass valve, this thermostatic valve can be installed on either the flow or return in any orientation. System automatic bypass valves are a specific building regulation requirement for all new installations and boiler upgrades. All bidirectional TRV's from any manufacturer require the bypass valve to function correctly and thus avoid radiator hammer.